

# SYNTECH ANTENNA SIGNAL SIMULATOR

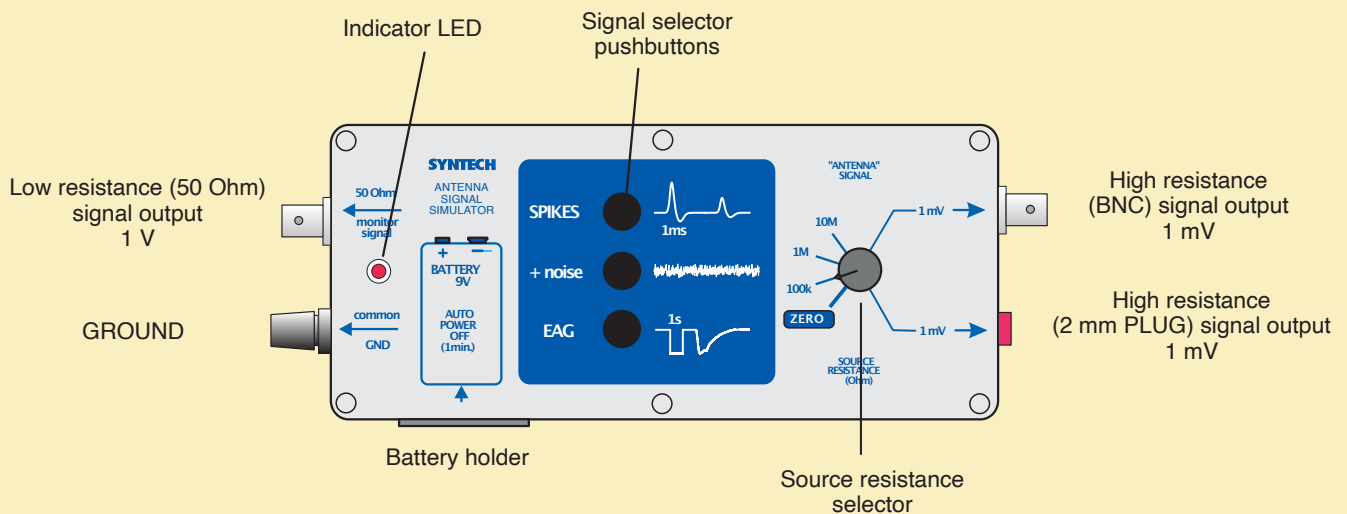

## INSTRUCTIONS

### A) Device test:

1. Insert 9 V battery
2. Connect Low resistance output (1 V ) to an oscilloscope input.
4. Set the oscilloscope to a fast time base speed.
5. Press the pushbutton for 'Spikes'
6. The LED flashes and spike bursts with amplitudes of 1 and 0.5 V are visible
7. Set the oscilloscope to a slow time base speed
8. Press the pushbutton for 'EAG'
9. The LED is on and a 1V block pulse followed by an EAG are visible
10. Press the 'noise' button to superimpose noise on the signal.

### B) Operation:

1. Connect the high resistance output (using the tests leads supplied with the crocodile clamps) to the input of the probe to be tested:
  - \* the black wire to the indifferent input (usually ground)
  - \* the RED wire to the different input (usually the recording electrode)

Place the whole device inside the Faraday cage  
Make sure the recording electrode is not connecting any metal.
2. Select 100 k source resistance
3. Prepare the recording and display device to show the EAG or spike signal.
4. Press the EAG or the Spikes pushbutton.
5. Check the signal at the display device of the recording system
6. Switch the source resistance to 1 M
7. Check the signal quality for noise induction etc.
8. Switch to 10 M resistance; observe increased noise susceptibility.
9. Return to 1 M resistance and select the best filter settings.
10. Switch to 'ZERO' to test the base line level (in DC mode only).

#### Remarks:

- \* The device is enclosed in a metal box to prevent noise interference with the high resistance output; However, the wires from this output are NOT shielded and thus susceptible to noise (50 Hz etc.); Therefore, the device must be placed inside the Faraday cage at the same location as the antennal preparation.
- \* At 10 Mohm source resistance most systems do not perform adequately and show a high noise level and poor signal to noise (S/N) ratio; this is normal.  
At 1 Mohm source resistance the S/N ratio should be acceptable or good.
- \* It is not possible to check the 1mV output signal on an oscilloscope, because of the resistance mismatch.
- \* If no button is pressed within one minute the device switches off automatically.

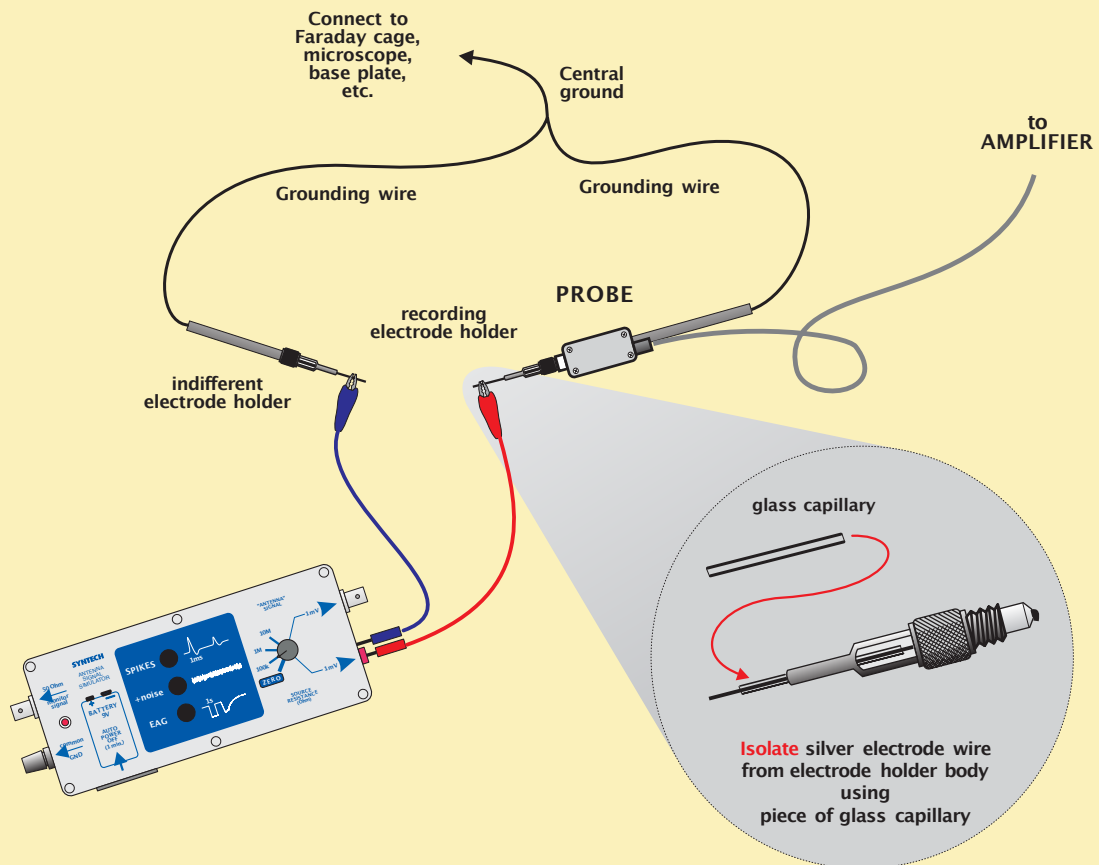

**GLASS ELECTRODE INPUT CONFIGURATION**

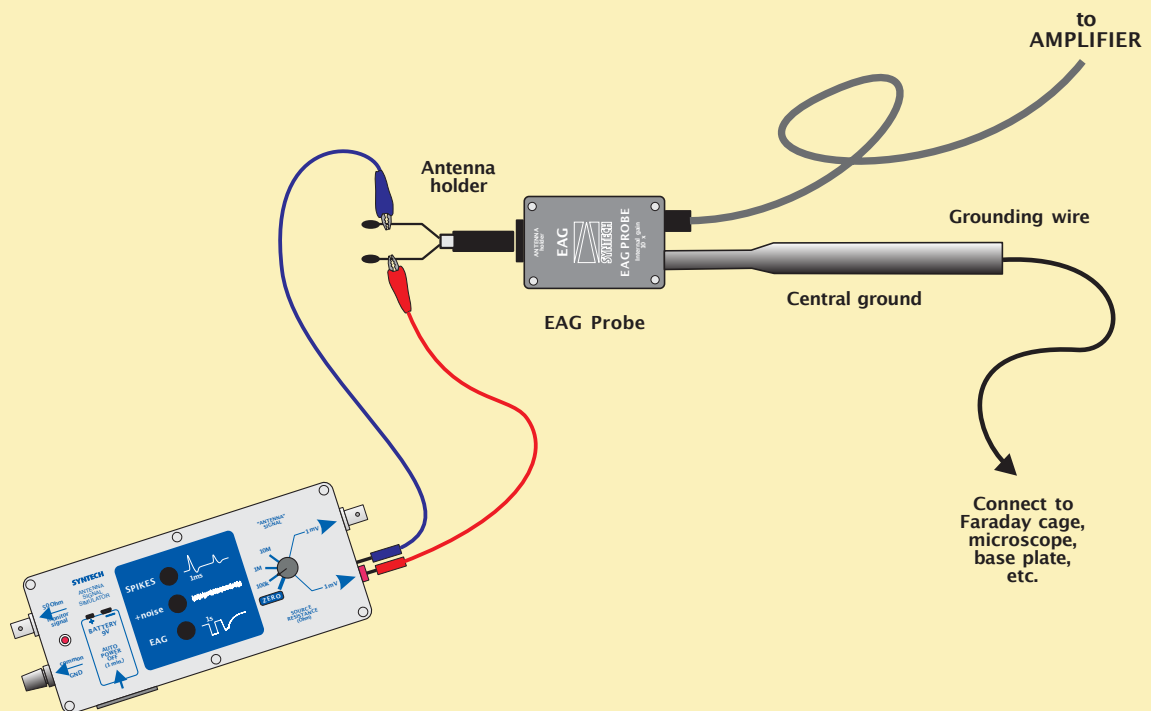

**EAG PROBE WITH 'GEL' ANTENNA HOLDER**